



AIR ACTIVITIES BADGE

 Name: _____
 Six: _____
 Cub Pack: _____

1

Section 1: Airfields Can Be Dangerous Places!

1

Know the dangers involved in visiting an airfield.
Read the statements below and tick the correct answer.

1. An aeroplane on the ground is taxiing towards you. Should you...?

- Run away?
- Stand still?
- Lie down?

2. You should never drop litter, but why is it especially important not to drop litter on an airfield?

- It makes the airfield look untidy.
- Rubbish might blow off the airfield into someone's garden.
- Pieces of litter could get sucked into jet engines and damage them.

3. A winch cable, for launching gliders, is lying on the ground. Should you...?

- Leave it alone?
- Pick it up and practice tying knots with it?
- Attach it to something, such as another cub scout?

4. A jet aeroplane is standing on the tarmac with its engine running. Where is safe to stand?

- In front of the jet intake.
- Behind the jet exhaust.
- To the side of the aircraft and well clear.

5. You are waiting for a helicopter to land. Should you...?

- Stand on the spot where it is going to land so that you get a good view?
- Run towards it as it descends?
- Keep well away and wait for the rotors to stop and the pilot to signal it's safe before you approach it?

6. You see a red triangle near the cockpit of a jet aeroplane. What does it mean?

- Ejector seat.
- Don't climb on the aircraft.
- Nothing – it's just a pretty pattern.

7. A light aircraft is being serviced in a hangar. Is it safe to...?

- Turn the propeller by hand?
- Get into the cockpit and try the controls?
- Assume that the aircraft is a dangerous place and keep well clear?

2

Section 2: Visit an air museum

2

By visiting the RAF Museum, London you have completed section 2 of your Air Activities Badge.

3

Section 3: Activities

3

For Section 3 you will need to complete 3 activities. There are several to choose from, but this booklet will guide you through 3 (c, e & g) to help you along.

If you decide to complete any of the other activities you may find that a visit to the museum shop could help you. There are model aeroplanes, books and pictures which can help you complete the other activities.

Choose
3
activities
to
complete

- a. Make and fly one of the following: a model aeroplane, three different types of paper glider, a hot-air balloon, or a kite.
- b. Identify six airlines and their nationalities from their markings.
- c. **Name and identify the main parts of an aeroplane.**
- d. Assemble a plastic scale model aeroplane to a reasonable standard.
- e. **Name and identify the different types of aircraft (powered aeroplanes, airships, gliders etc.).**
- f. Fly in an aircraft and share your experience with the Pack.
- g. **Explain how different weather conditions can affect air activities.**
- h. Collect and identify six different pictures of aircraft and share them with other Cub Scouts.

Learning about the controls on an aeroplane will help you to get better acquainted with the different parts of the plane.

Find the large model aeroplane in the Aeronauts Interactive Gallery.

Instruction	Model Plane Response	Real Plane Response
Pull control column backwards.	_____ move up.	The plane climbs.
Push control column forwards.	_____ move down.	The plane dives.
Push control column left.	Port (left) _____ goes up and the starboard (right) _____ goes down.	The plane banks (tilts) left allowing the pilot to change direction.
Push control column right.	The port aileron goes _____ and the starboard aileron goes _____.	The plane rolls to the right.
Push left pedal forwards.	The _____ moves to the left.	The plane will turn left if it is also banked to the left.
Push right pedal forwards.	The rudder moves to the _____.	The plane will turn right if it is also banked to the right.

3c

Activity 3c: Parts of an Aeroplane

3c

Fill in the spaces using the words below:

Fuselage – the body of an aeroplane

Wing – the part which supports the aeroplane when flying

Tailplane – small horizontal wing at the tail of the aeroplane

Fin – the upright surface on the tail

Undercarriage – the landing gear and wheels

Cockpit – where the pilot sits

Rudder – hinged rear part of the fin which helps the pilot to steer

Aileron – hinged rear edge of the wing

Elevator – hinged rear part of the tailplane

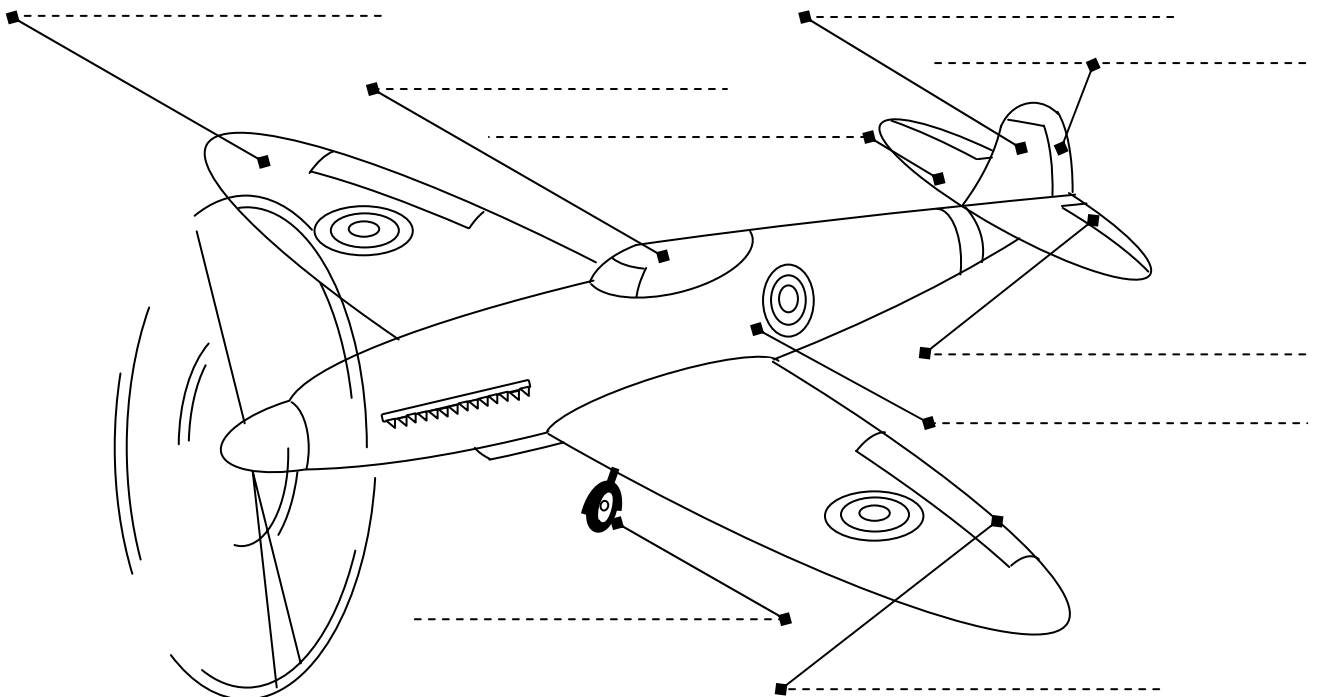

You can find out more about how aircraft fly by trying the exhibits in the Aeronauts Interactive Gallery. Find examples of different types of aircraft in the museum.

3e

Activity 3e: Identifying Aircraft

3e

Find examples of the different types of aircraft listed below:

All flying machines are **aircraft**.

Aircraft can be **lighter** than air or **heavier** than air.

Balloons and **airships** are filled with gas or hot air which is lighter than the air around them.

Gliders use rising currents of air to stay up

Aeroplanes use the shape of their wings to obtain lift.

Some aeroplanes have more than one set of wings.
One set of wings is a **monoplane**.
Two sets of wings is a **biplane**.

Helicopters have **rotary wings** which lift the aircraft by whirling round.

Where can you see a **Hot Air Balloon**? _____

You won't be able to find an **Airship**, but if you look up you might find the **Control Car** from one. Which **Airship** did it belong to? _____

Fill in the name of an aircraft in the Museum that is a:

Biplane _____

Monoplane with propeller _____

Twin engined aeroplane _____

Jet-propelled aeroplane _____

Helicopter _____

Flying Boat _____

Four engined aeroplane _____

Glider _____

3g

Activity 3g: Weather and Flight

3g

Match each weather condition to the correct statement about flight

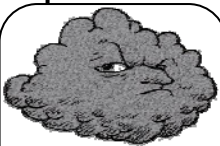

Thick Fog

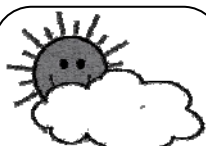

Warm Sun



Temperature below freezing at ground level



Thunder and Lightning



Very Strong Winds



Snow

Perfect for gliding

De-ice aircraft before flight

Wait for improved visibility before taking off

Clear runway before aircraft land or take off

Ideal conditions for ballooning

Bumpy conditions for flight